

This product complies with NSF61/9, ASME/ANSI A112.18.1 and CSA B 125 Standards.
Este producto se encuentra conforme con los estándares de NSF61/9, de ASME/ANSI A112.18.1 y de CSA B 125.

Installation Instructions ● Instrucciones de Instalación

Dear Customer

Thank you for selecting our product. We are confident we can fully satisfy your expectations by offering you a wide range of technologically advanced products which directly result from our many years of experience in faucet and fitting production.

ENGLISH

Estimado Cliente

Muchas gracias por elegir nuestro producto. Estamos seguros que podemos satisfacer completamente sus expectativas ofreciéndole una amplia variedad de productos tecnológicamente avanzados que resultan directamente de muchos años de experiencia en grifos y su producción apropiada.

ESPAÑOL

ATTENTION!

For care, use soft towel with soap and water only! Under no circumstances should you use any chemicals.

ATENCIÓN!

Para el cuidado, utilice solamente una toalla suave con jabón y agua! Bajo ninguna circunstancia no use productos químicos.

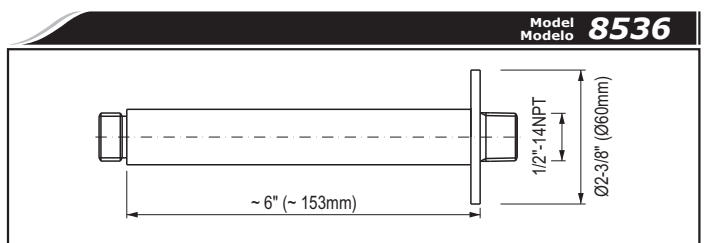
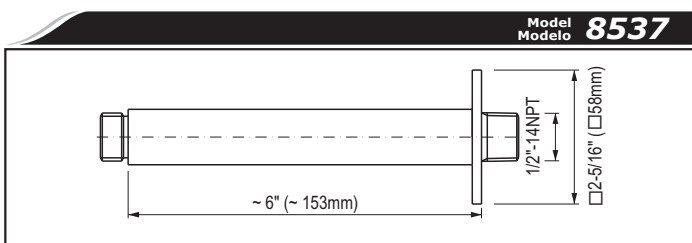
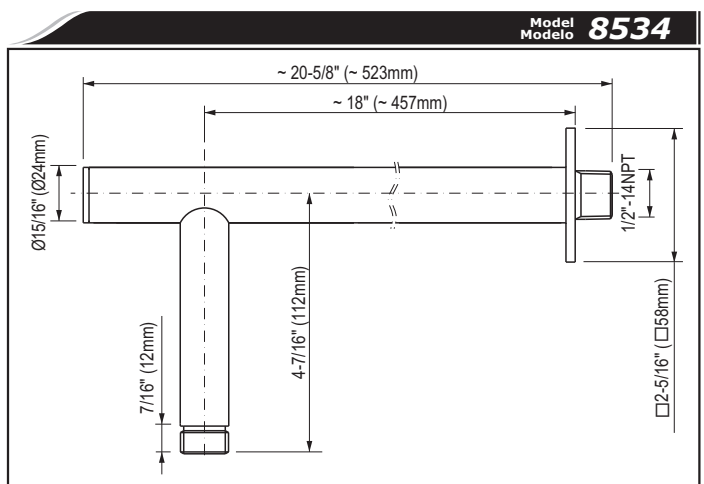
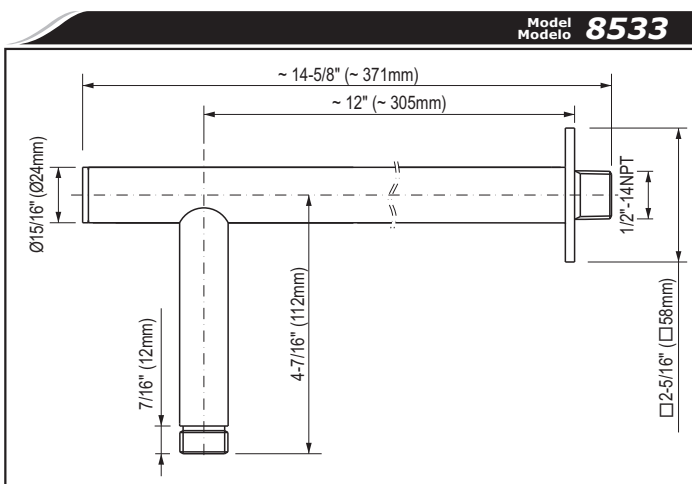
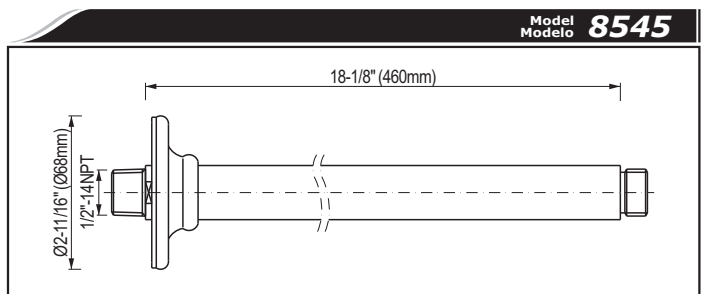
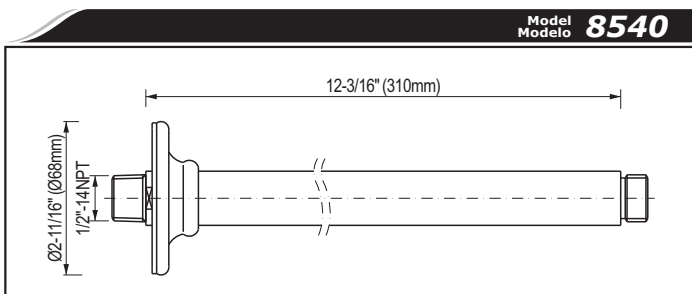
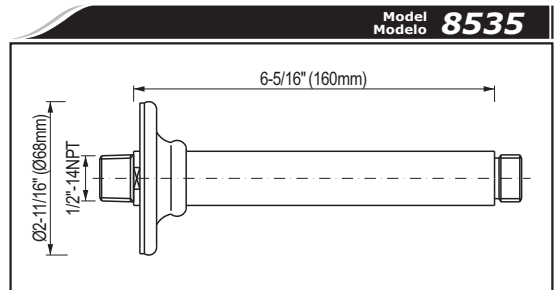
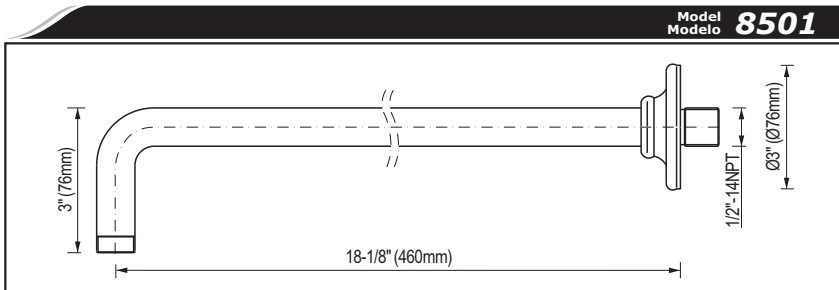
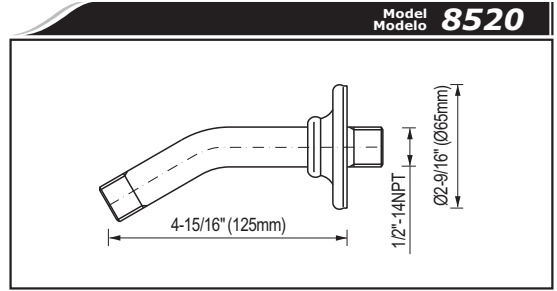
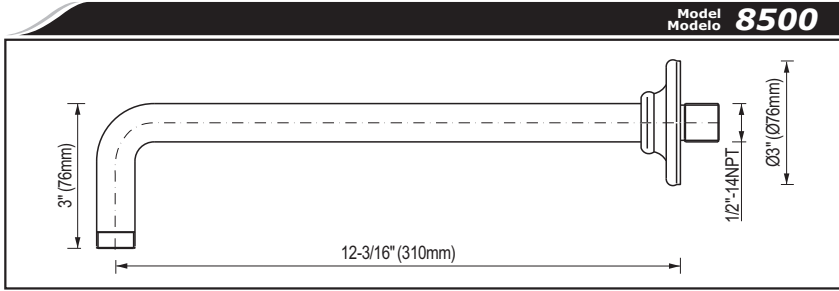

This product complies with NSF61/9, ASME/ANSI A112.18.1 and CSA B 125 Standards.
Este producto se encuentra conforme con los estándares de NSF61/9, de ASME/ANSI A112.18.1 y de CSA B 125.

Installation Instructions ● Instrucciones de Instalación

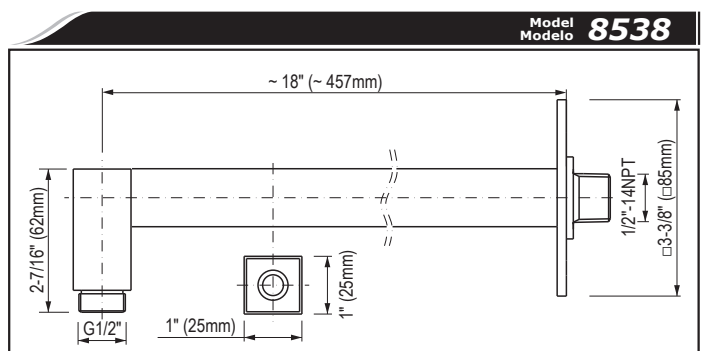
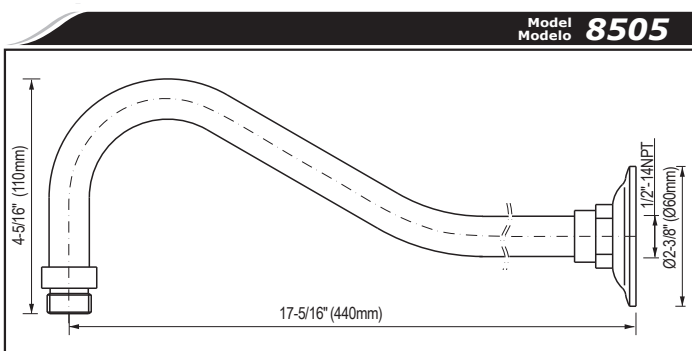
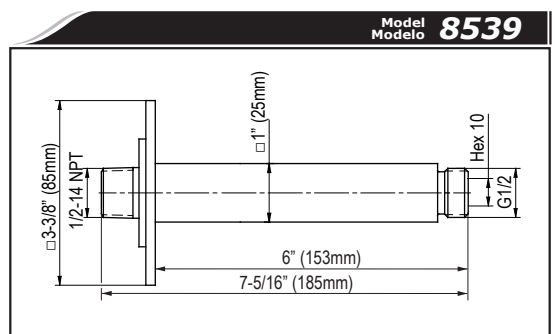
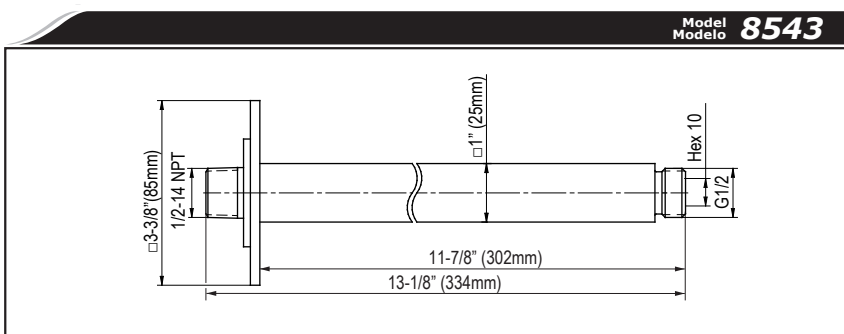
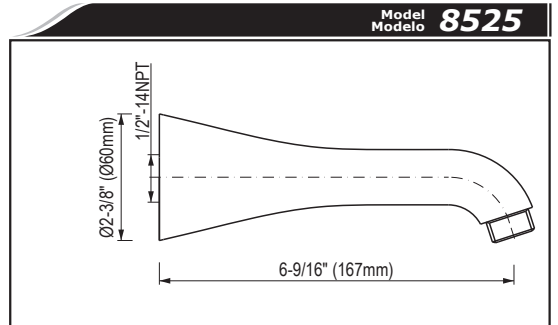
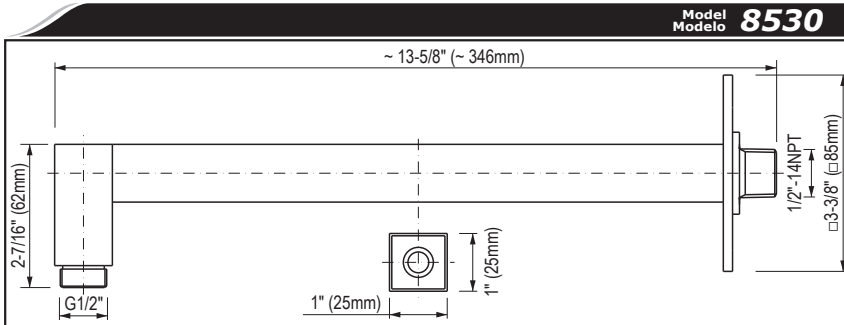
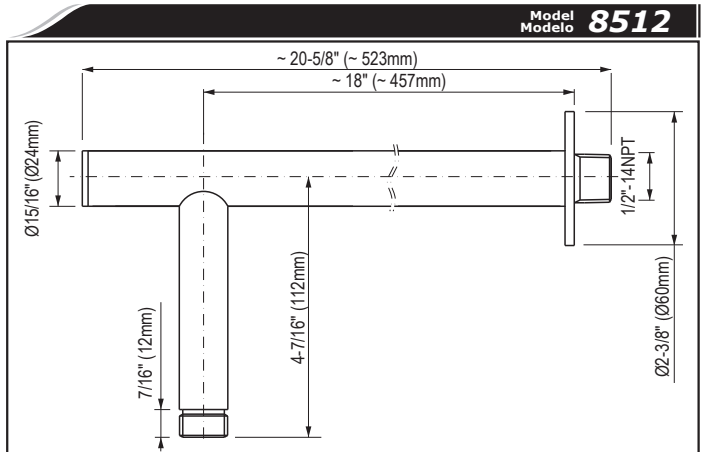
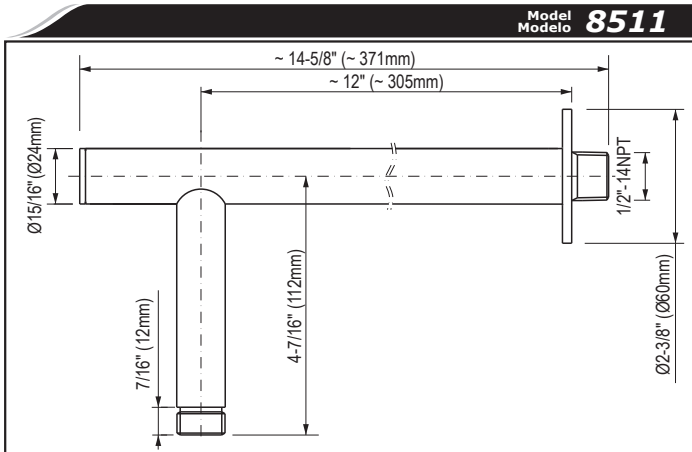
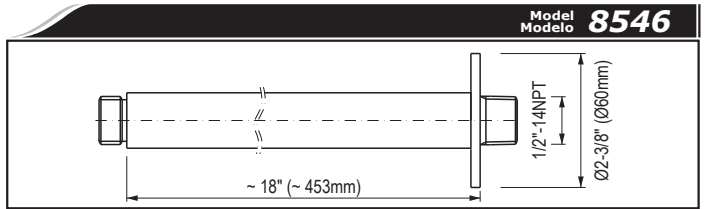
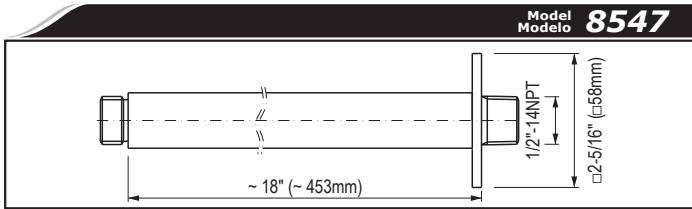
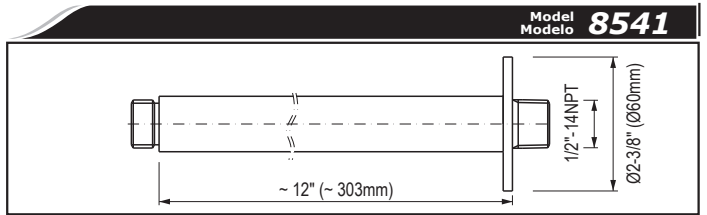
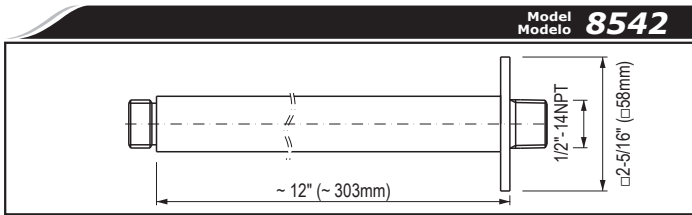

This product complies with NSF61/9, ASME/ANSI A112.18.1 and CSA B 125 Standards.
Este producto se encuentra conforme con los estándares de NSF61/9, de ASME/ANSI A112.18.1 y de CSA B 125.

Installation Instructions ● Instrucciones de Instalación

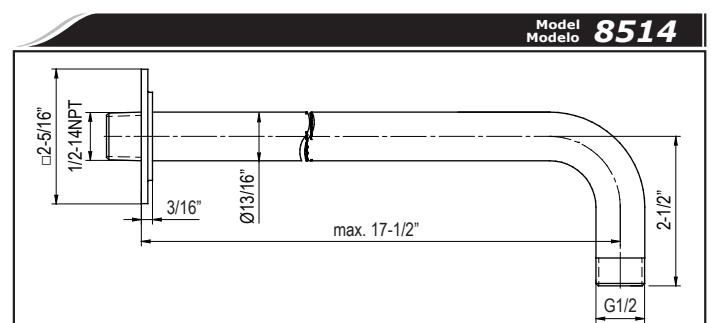
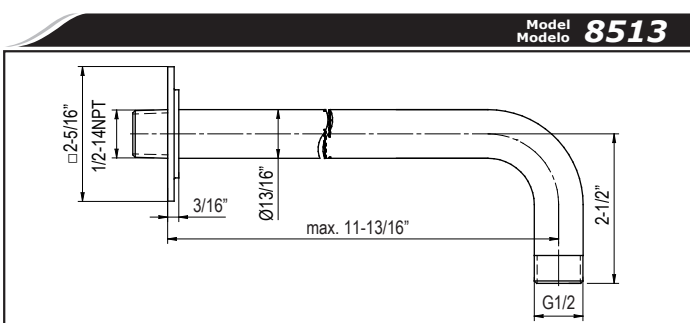
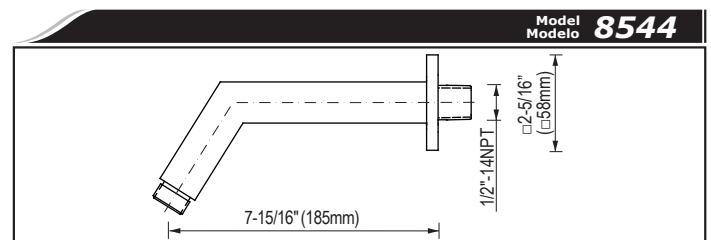
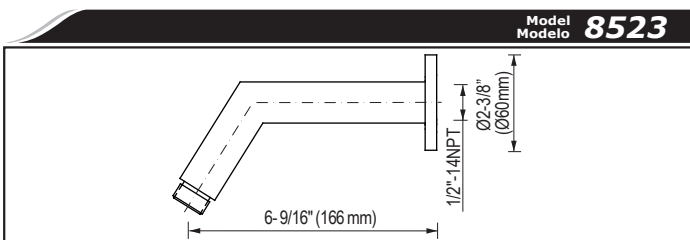
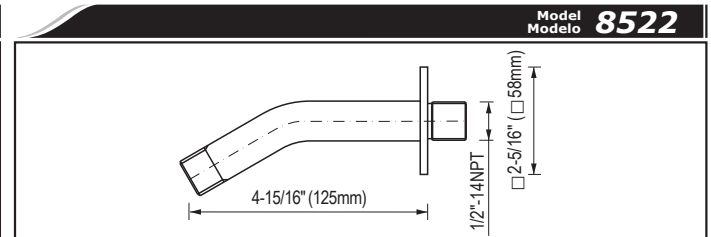
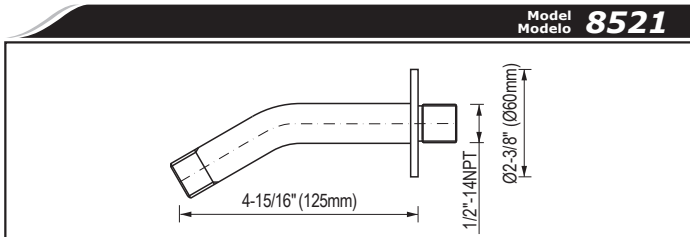
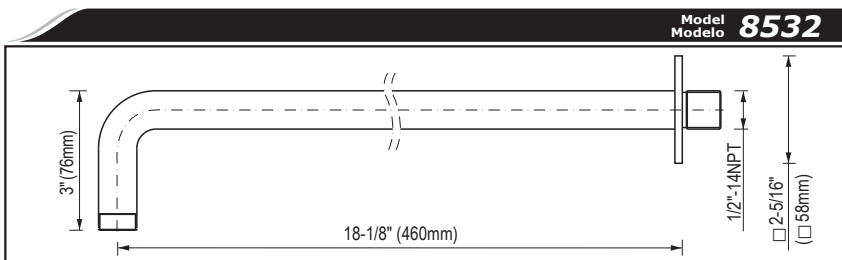
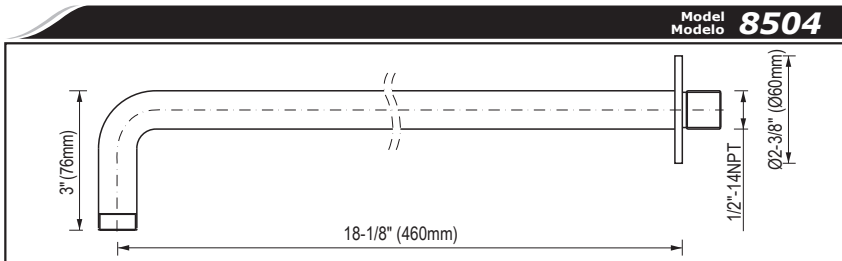
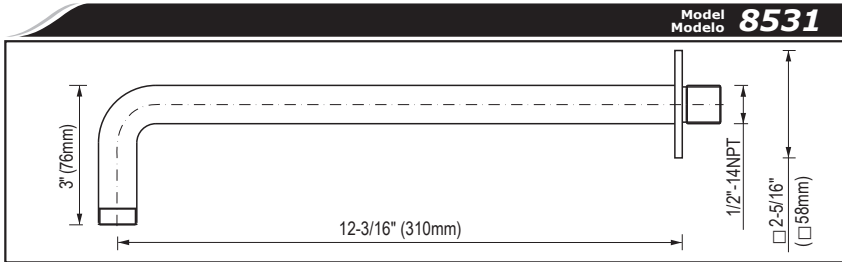
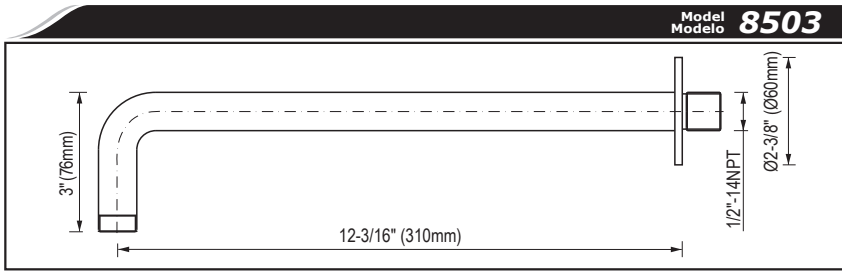

ENGLISH

➔ For easy installation of your GRAFF faucet you will need:

- to READ ALL the instructions completely before beginning,
- to READ ALL the warnings, care and maintenance information.

➔ To complete the project, you should:

- gather the tools and all the parts you will need,
- prepare the mounting area,
- mount the faucet,
- connect the supply lines,
- finally test and flush the faucet.

➔ You should have the following tools:

- adjustable wrench,
- strap wrench,
- 1/2" pipe connector,
- plumbers putty.

ESPAÑOL

➔ Para la instalación fácil de su grifo de la GRAFF usted necesitará:

- LEER TODAS las instrucciones completamente antes de comenzar,
- LEER TODA la información sobre las advertencias, cuidado y mantenimiento.

➔ Para terminar el proyecto, usted debe:

- recolectar las herramientas y todas las piezas que usted necesitará,
- prepare el área para el montaje,
- monte el grifo,
- conecte las líneas de fuente,
- finalmente pruebe y limpie el grifo con un chorro de agua.

➔ Usted debe tener las herramientas siguientes:

- llave ajustable,
- llave de correa,
- pieza de empalme de 1/2",
- masilla de plomería.

This product complies with NSF61/9, ASME/ANSI A112.18.1 and CSA B 125 Standards.
Este producto se encuentra conforme con los estándares de NSF61/9, de ASME/ANSI A112.18.1 y de CSA B 125.

Installation Instructions ● Instrucciones de Instalación

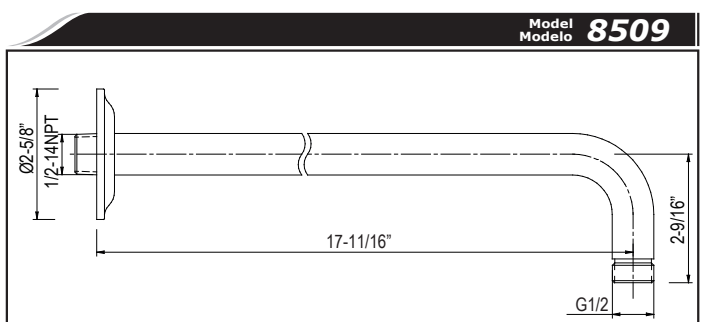
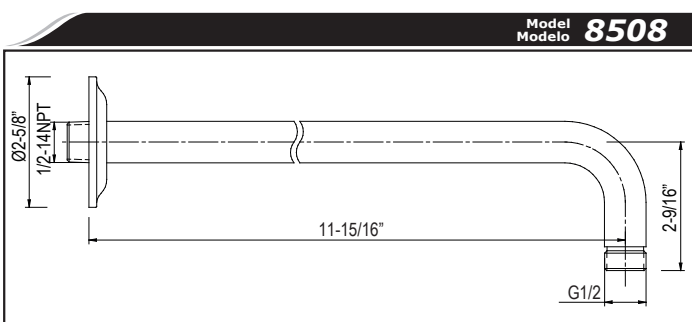
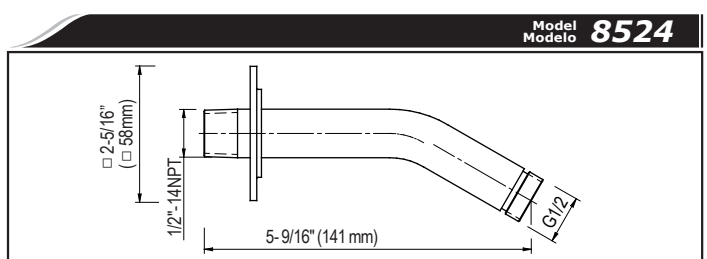
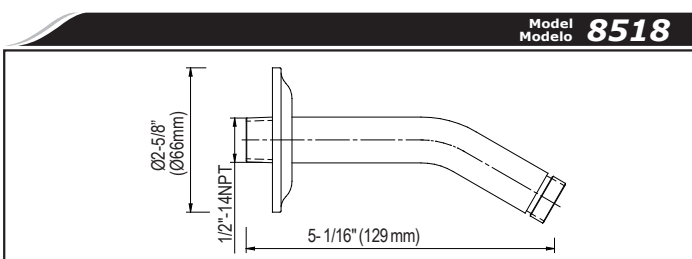
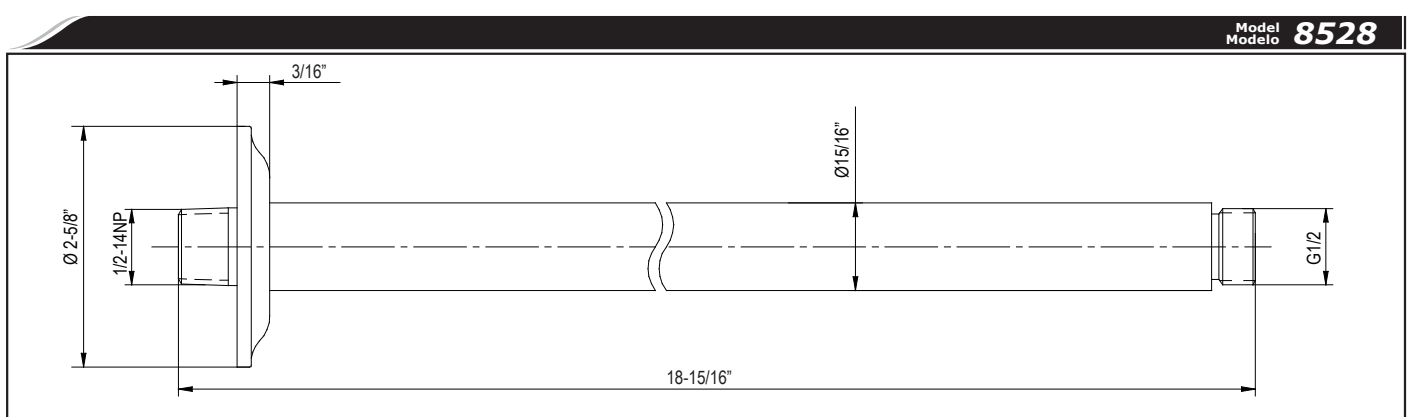
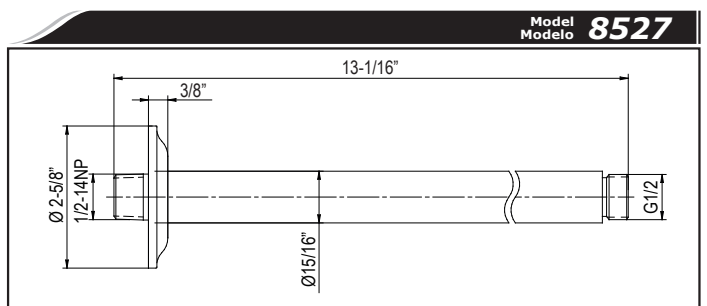
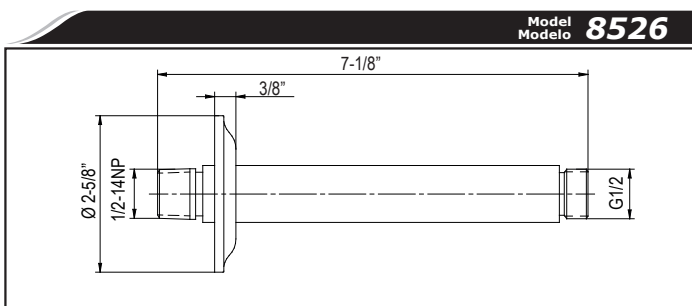
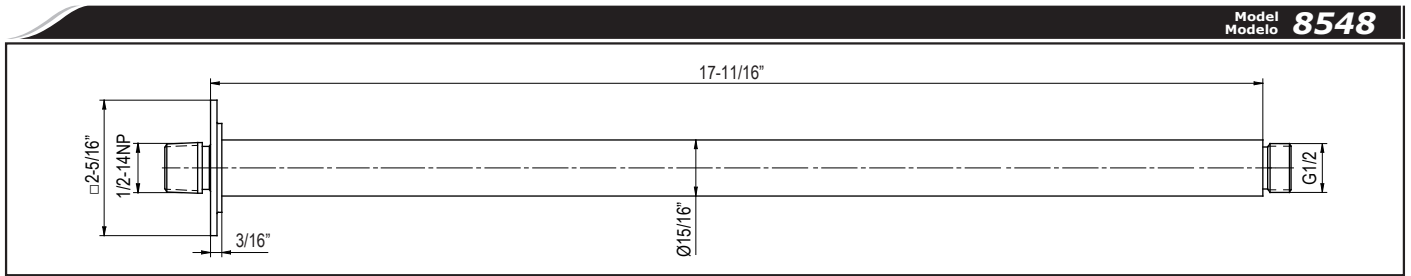
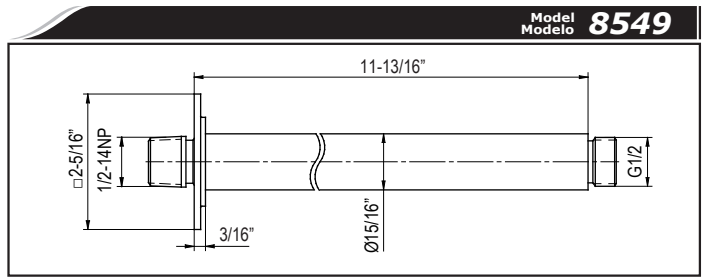
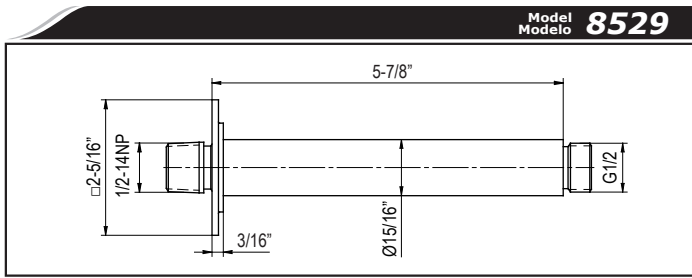

This product complies with NSF61/9, ASME/ANSI A112.18.1 and CSA B 125 Standards.
Este producto se encuentra conforme con los estándares de NSF61/9, de ASME/ANSI A112.18.1 y de CSA B 125.

Installation Instructions ● Instrucciones de Instalación

SHOWER ARM INSTALLATION ● INSTALACIÓN DE LA BRAZO DE REGADERA

ENGLISH

ESPAÑOL

See fig. 1a, 1b & 1c

Vea fig. 1a, 1b y 1c

1. Connect top outlet to shower arm with proper fittings. Install a 1/2" pipe nipple connector (**A1**) (or 1/2" pipe connector with inner thread (**A2**)) for the shower arm (**C**).
2. Run water through the system to flush out dirt and debris.
3. Apply thread sealant to the exposed pipe nipple threads.
4. Apply a bead of plumbers putty or other sealant to the back of escutcheon (**B**). The escutcheon (**B**) should fit to the the finished wall surface.
5. Thread the shower arm (**C**) to the pipe connector (**A1** or **A2**). Use strap wrench to carefully wrench tighten.
6. Remove any excess putty.

1. Conecte salida más alta al brazo de regadera con accesorios propios. Instale un niple de 1/2" de manera (**A1**) (u la pieza de empalme con rosca interna 1/2" (**A2**)) para brazo de regadera (**C**).
2. Haga correr el agua a través del sistema para eliminar los sedimentos y desechos.
3. Aplique sellador para rosca a las roscas expuestas del niple.
4. Aplique una tira de masilla de plomería u otro sellador en la parte inferior del chapetón (**B**). Deslice con cuidado el chapetón (**B**) y contra la pared acabada. El chapetón (**B**) debe caber cómodamente a la superficie acabada de la pared.
5. Encrosque de la brazo de regadera (**C**) al pieza de empalme (**A1** or **A2**). Utilice una llave de correa a una llave ajustable para fijar.
6. Remueva el exceso de masilla de plomería.

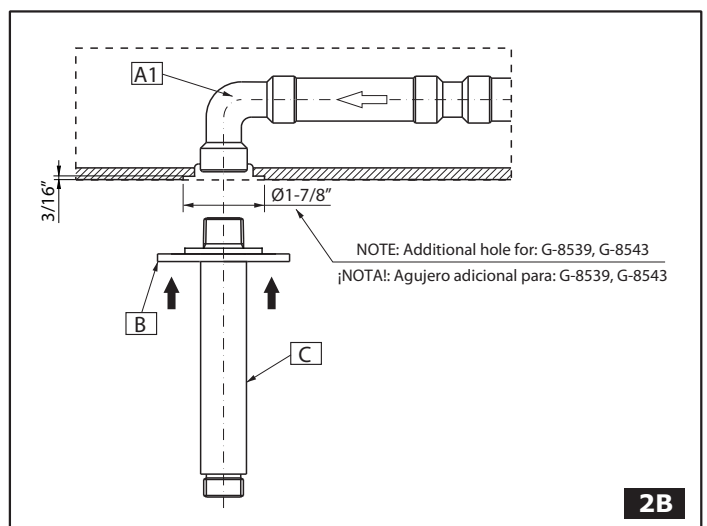
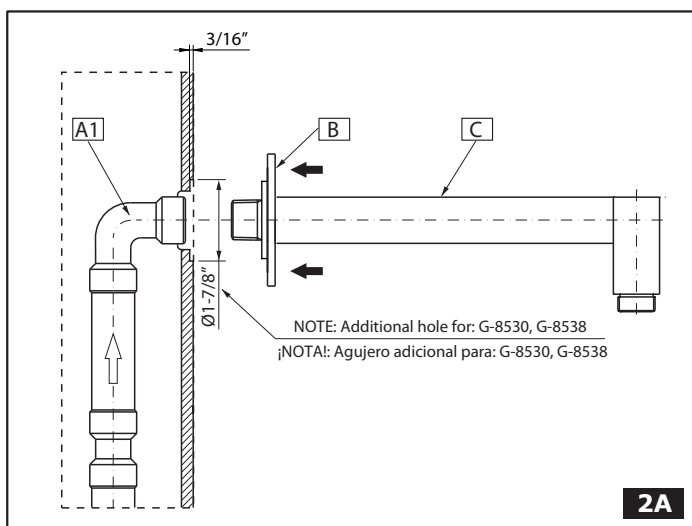
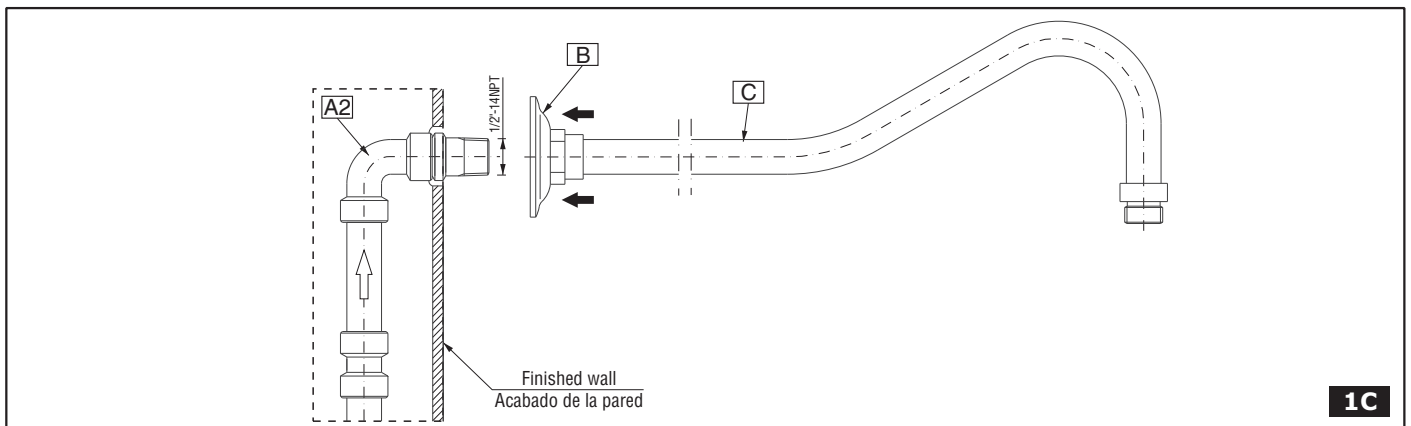
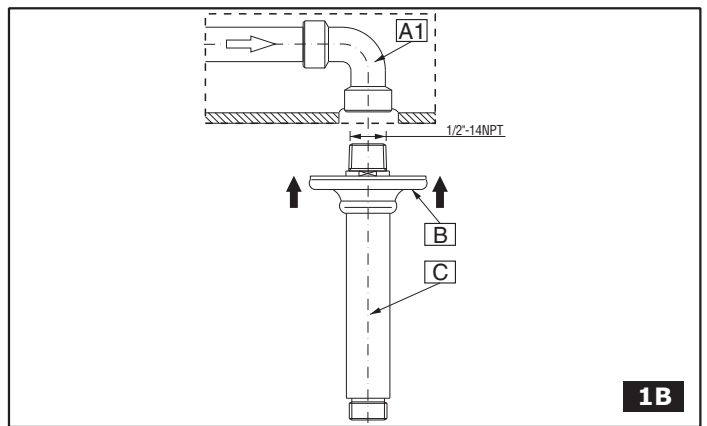
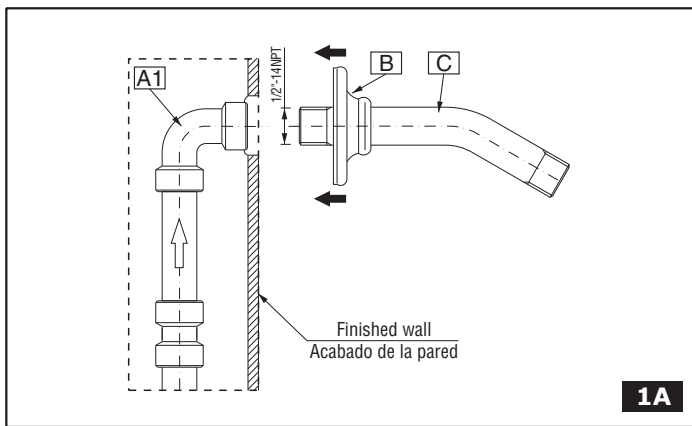

This product complies with NSF61/9, ASME/ANSI A112.18.1 and CSA B 125 Standards.
Este producto se encuentra conforme con los estándares de NSF61/9, de ASME/ANSI A112.18.1 y de CSA B 125.

Installation Instructions ● Instrucciones de Instalación

CARE AND MAINTENANCE ● CUIDADO Y MANTENIMIENTO

3

ENGLISH

ESPAÑOL

Your *Graff* product is designed and engineered in accordance with the highest quality and performance standards. Be sure not to damage the finish during installation. Care should be given to the cleaning of this product. Although its finish is extremely durable, it can be damaged by harsh abrasives or polish. **Never use abrasive cleaners, acids, solvents, etc. to clean any *Graff* product. To clean, simply wipe gently with a damp cloth and blot dry with a soft towel.**

Su producto de la *Graff* esta diseñado y dirigido acuerdo con los estándares de funcionamiento y calidad más altos. Este seguro no dañar las terminaciones del grifo durante la instalación. Cuide el producto manteniendolo siempre limpio. Aunque su acabado es extremadamente durable, puede ser dañado por los abrasivos o pulientes ásperos. **Nunca utilice limpiadores abrasivos, ácidos, solventes, el etc. para limpiar cualquier producto de la *Graff*. Para limpiar, simplemente use un paño húmedo y seque con una toalla suave.**

WARRANTY ● GARANTÍA

ENGLISH

ESPAÑOL

Warranty conditions and warranty registration card are outlined on a separate sheet.

Las condiciones de la garantía y la tarjeta del registro de la garantía se encuentran en una pagina separada.

**HOTLINE FOR HELP
NUMERO DE EMERGENCJA**

For toll-free information and answers to your questions, call:
Llame sin costo para obtener informacion y respuestas a sus preguntas:



1 - 800 - 954 - GRAF (4723)
www.graffcollection.com

All dimensions and drawings are for reference only. For details, please refer to actual products.
Todas las dimensiones y dibujos sirven únicamente de referencia. Para consultar detalles, ver los productos.

Dear Customer

Thank you for selecting our product. We are confident we can fully satisfy your expectations by offering you a wide range of technologically advanced products which directly result from our many years of experience in faucet and fitting production.

ENGLISH

Estimado Cliente

Muchas gracias por elegir nuestro producto. Estamos seguros que podemos satisfacer completamente sus expectativas ofreciéndole una amplia variedad de productos tecnológicamente avanzados que resultan directamente de muchos años de experiencia en grifos y su producción apropiada.

ESPAÑOL

ATTENTION! For care, use soft towel with soap and water only! Under no circumstances should you use any chemicals.

ATENCIÓN! Para el cuidado, utilice solamente una toalla suave con jabón y agua! Bajo ninguna circunstancia no use productos químicos.

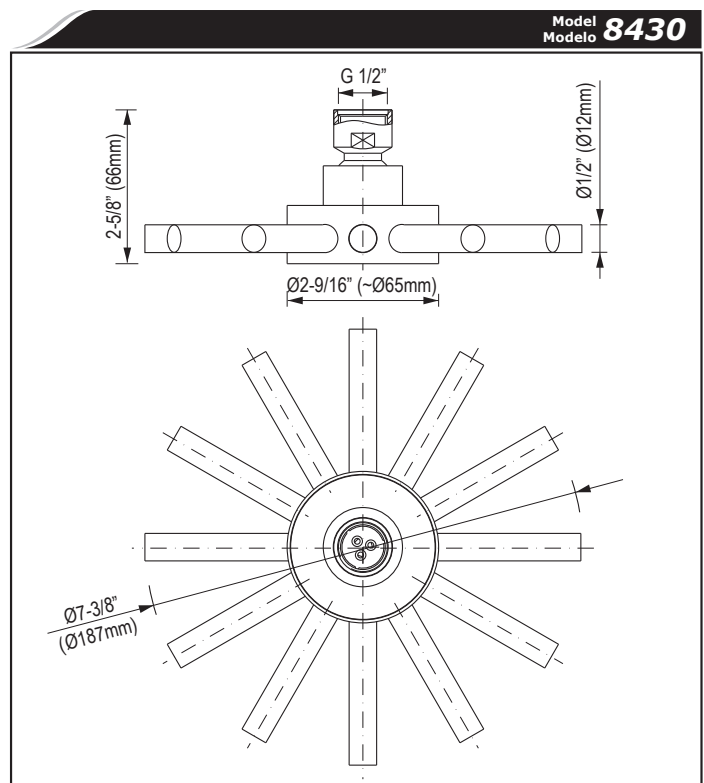
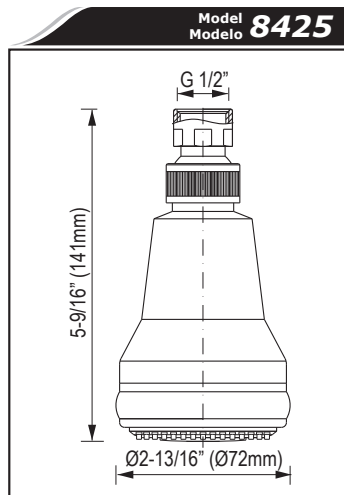
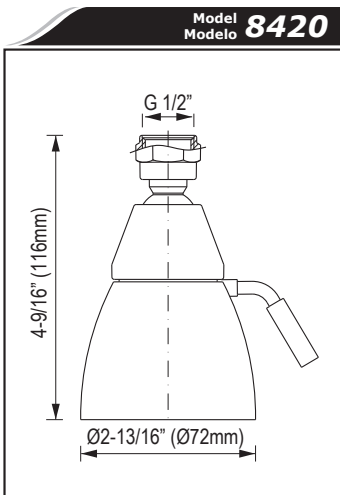
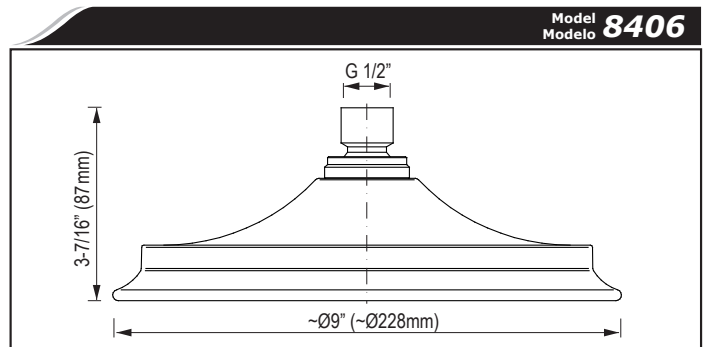
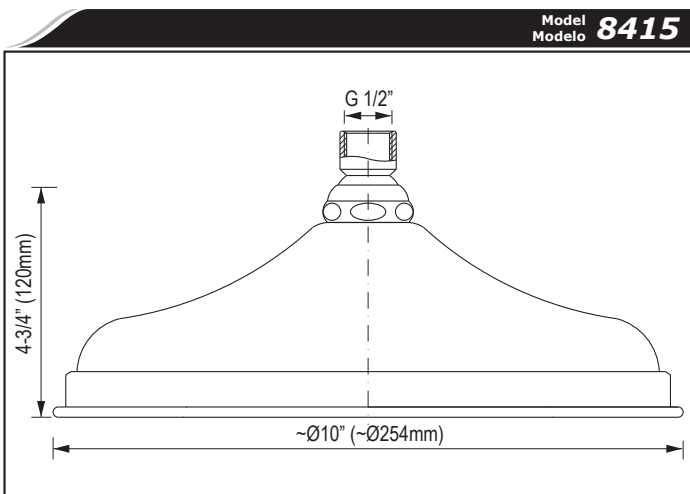
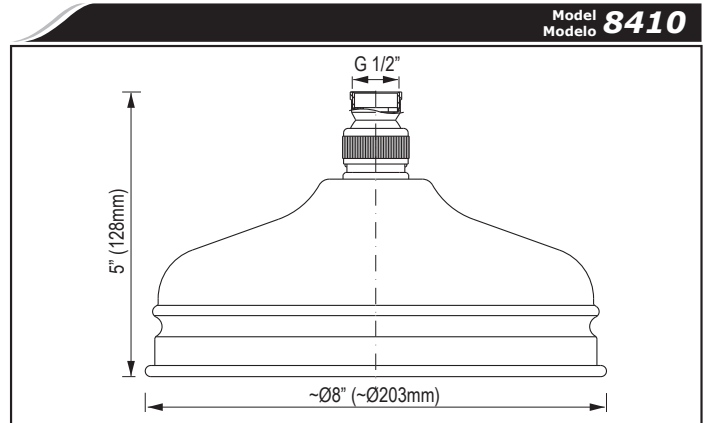
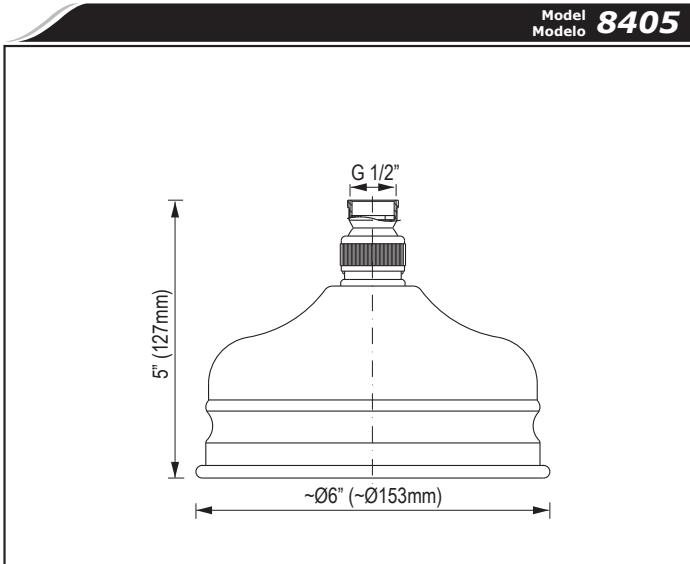

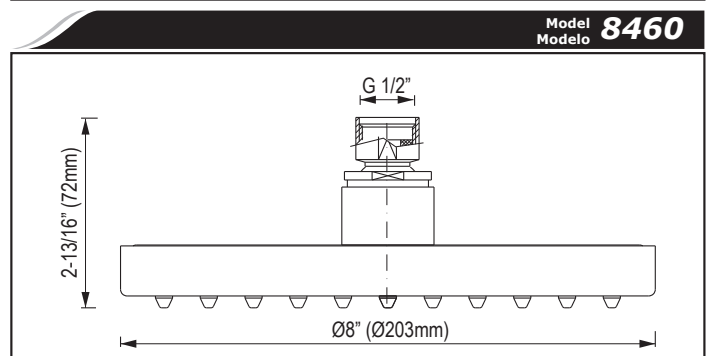
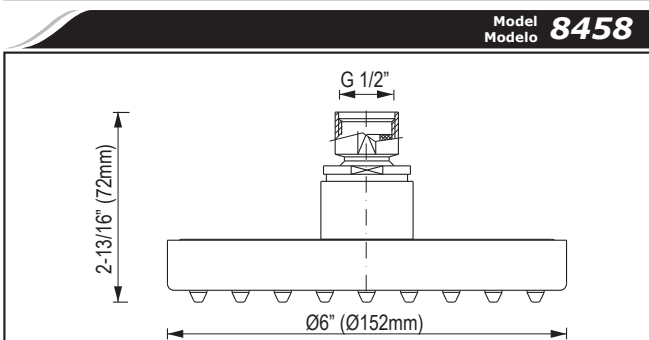
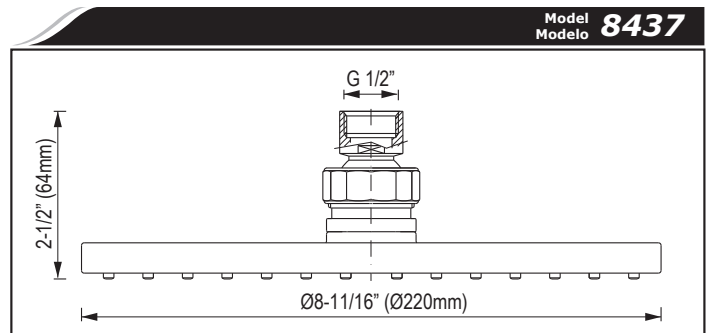
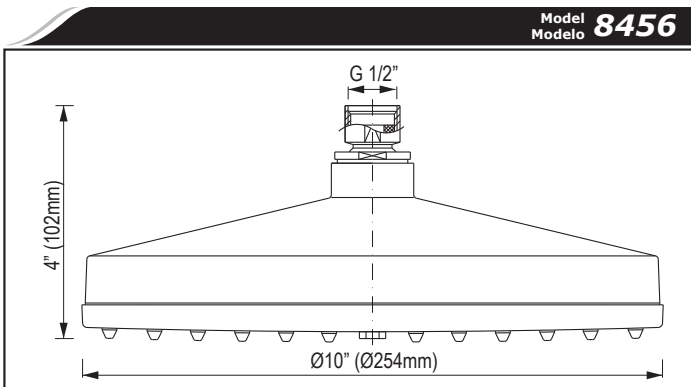
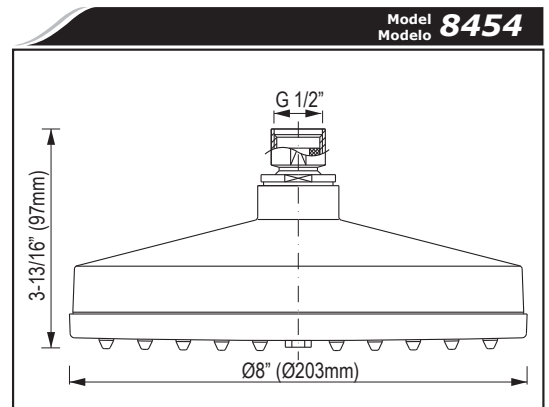
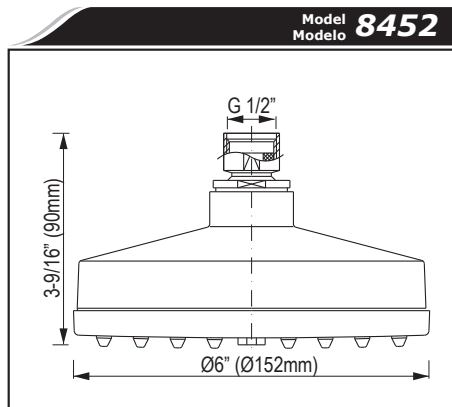
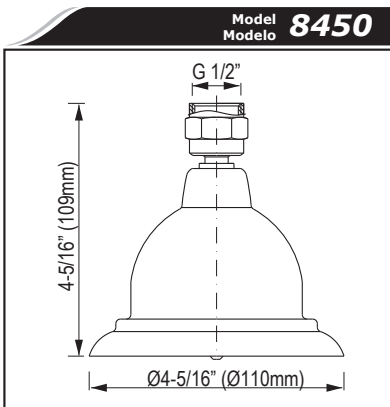
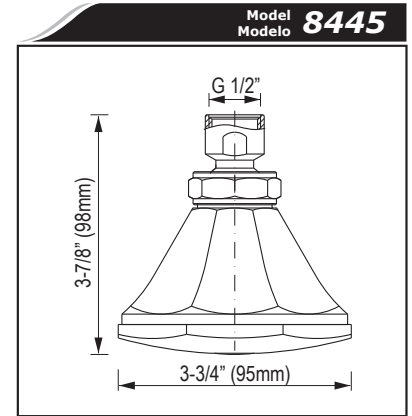
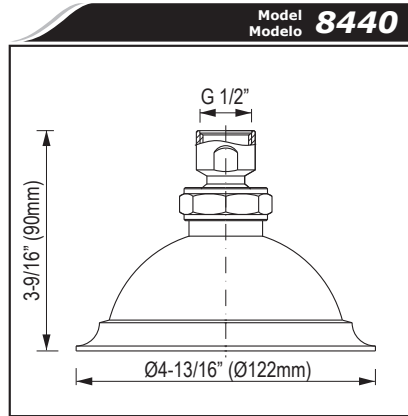
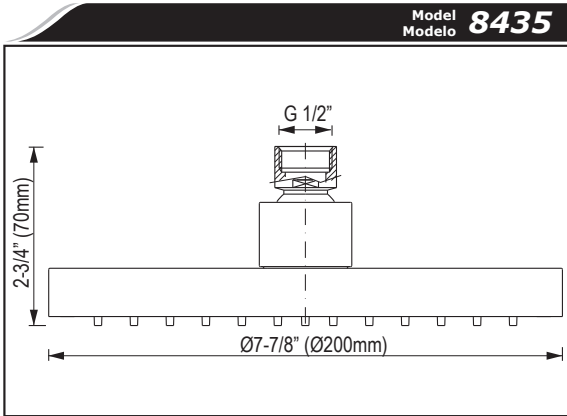

ENGLISH

→ You should have the following tools:

- adjustable wrench,
- strap wrench,
- Teflon[®] tape or plumbers putty.

ESPAÑOL

→ Usted debe tener las herramientas siguientes:

- llave ajustable,
- llave de correa,
- cinta adhesiva de Teflon[®] o masilla de plomería.

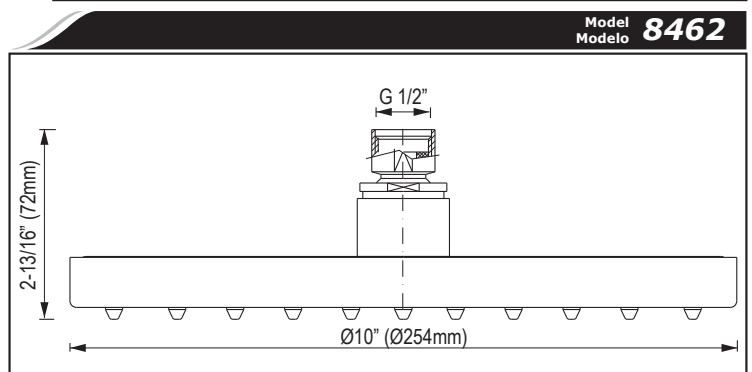

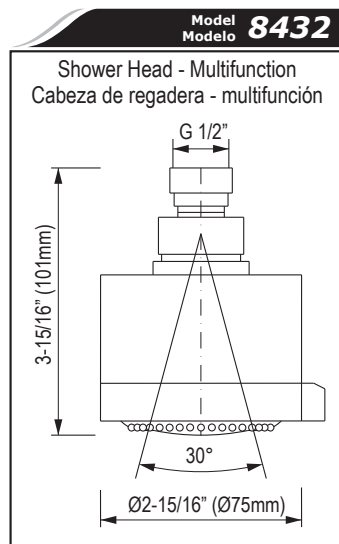
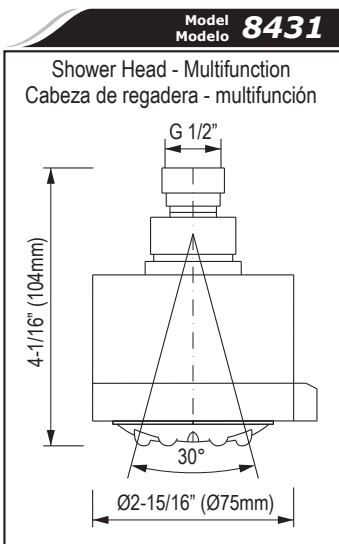
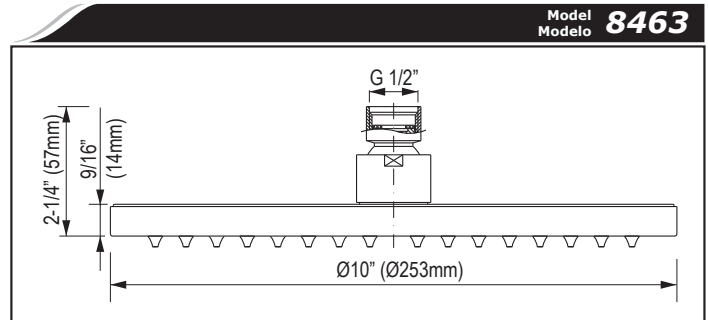
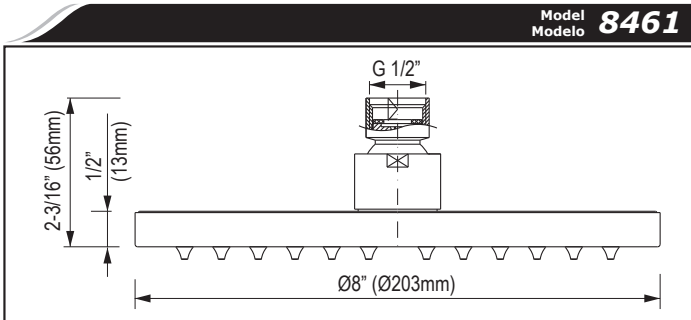
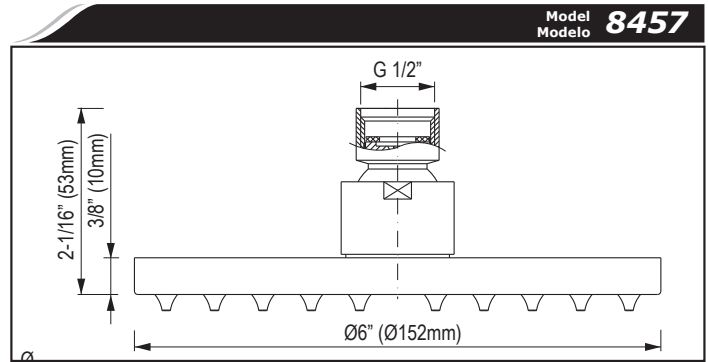
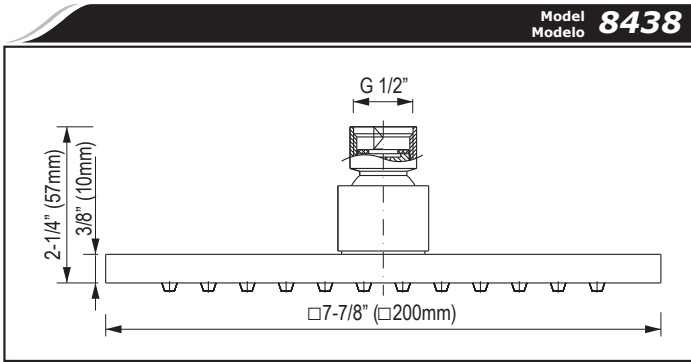

SHOWERHEAD INSTALLATION

ENGLISH

see fig. 1a & 1b & 1c

- Run hot and cold water through the shower arm to flush out dirt and debris.
- Apply thread sealant to the shower arm nipple.
- Thread the showerhead to the shower arm. Use a clean strap wrench to tighten the showerhead.
- Check the showerhead for smooth operation.

INSTALACIÓN EL CABEZAL DE LA REGADERA

ESPAÑOL

vea fig. 1a y 1b & 1c

- Abra el agua caliente y fría en el brazo de la regadera para eliminar cualquier desecho.
- Aplique sellador para rosca al niple del brazo de la regadera.
- Enrosque el cabezal al brazo de la regadera. Utilice una llave de correa para fijar el cabezal.
- Verifique que el cabezal de la regadera funcione adecuadamente.

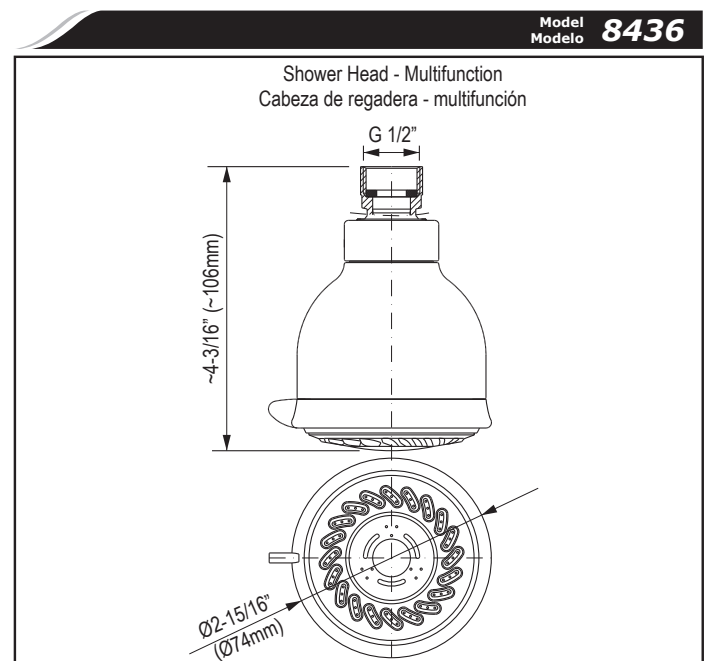
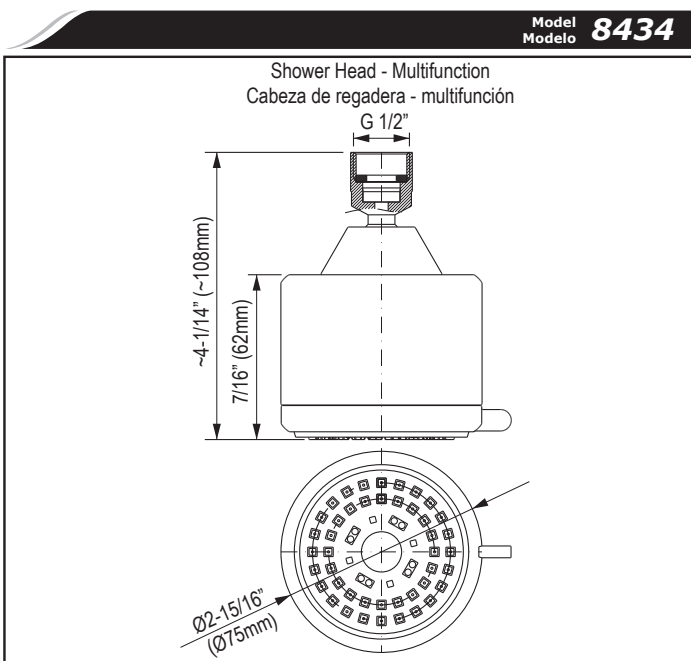

Model
Modelo **8424**

Shower Head - 3 function
Cabeza de regadera - 3 función

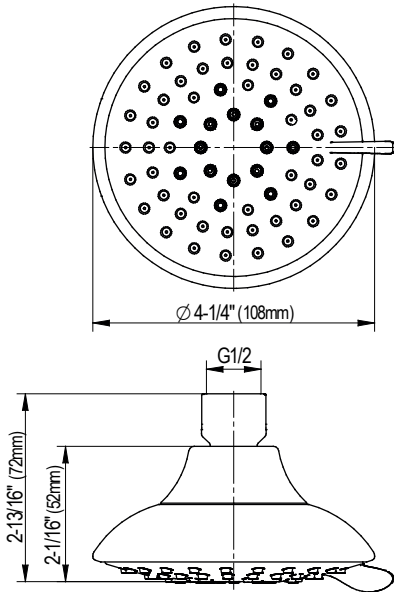

Model
Modelo **8426**

Shower Head - 3 function
Cabeza de regadera - 3 función

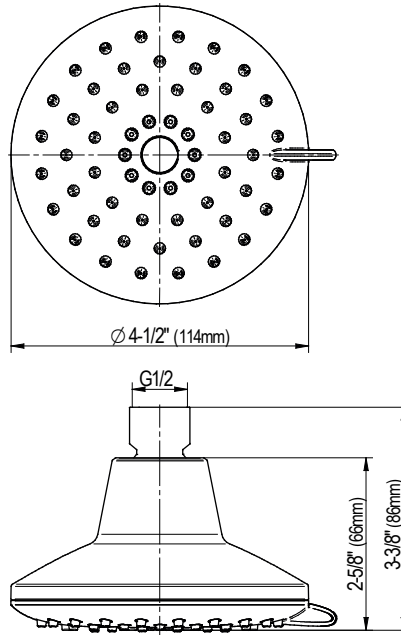

Model
Modelo **8427**

Shower Head - Multifunction
Cabeza de regadera - multifunción

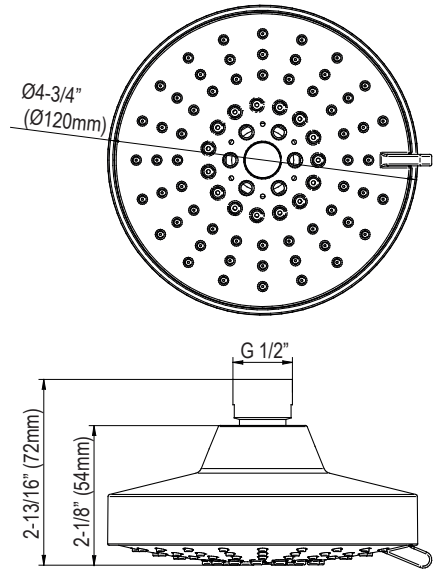

Model
Modelo **8428**

Shower Head - Multifunction
Cabeza de regadera - multifunción

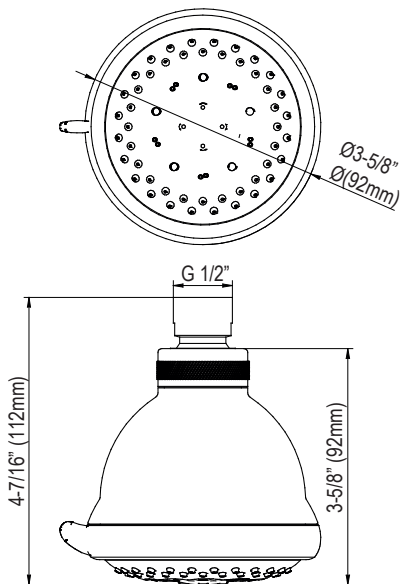

Model
Modelo **8429**

Shower Head - Multifunction
Cabeza de regadera - multifunción

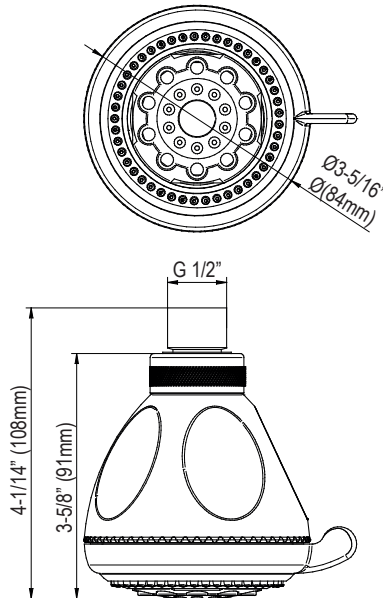

Model
Modelo **8433**

Shower Head - Multifunction
Cabeza de regadera - multifunción

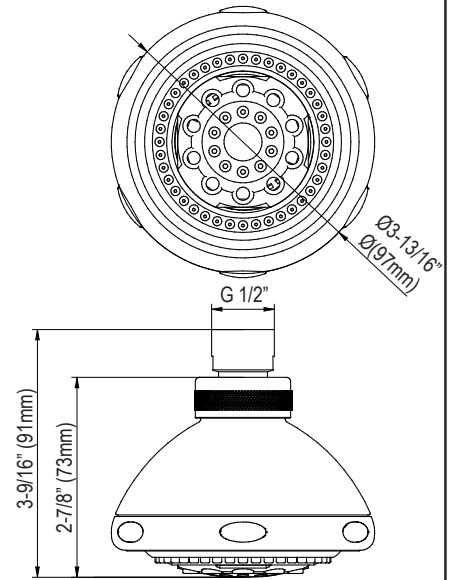

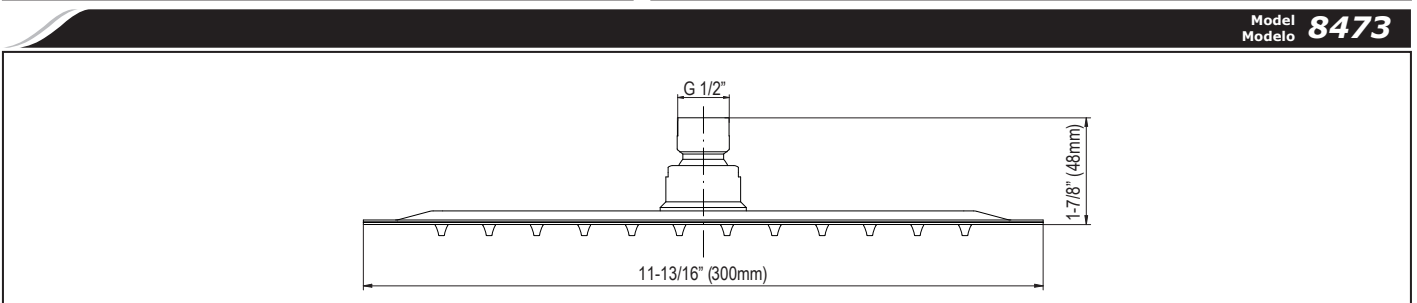
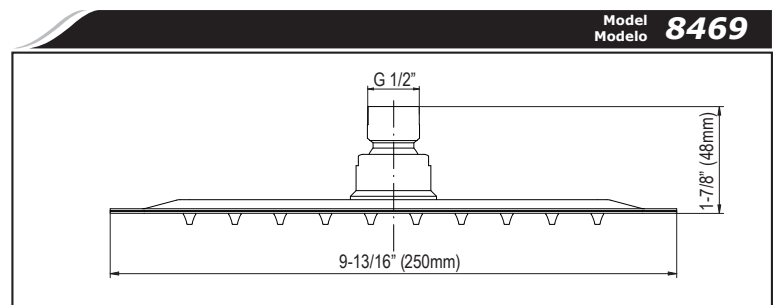
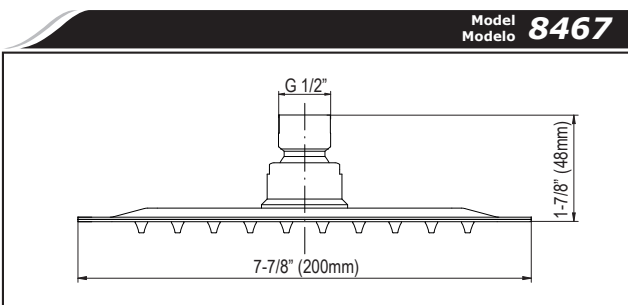
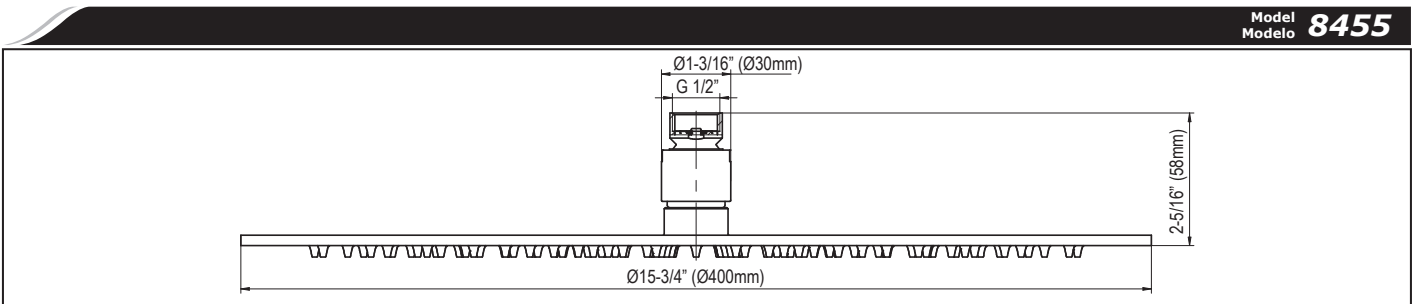
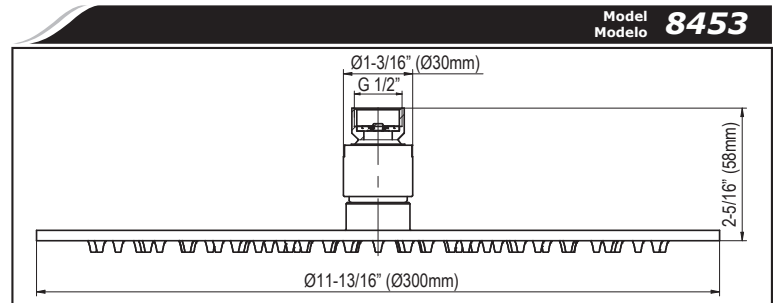
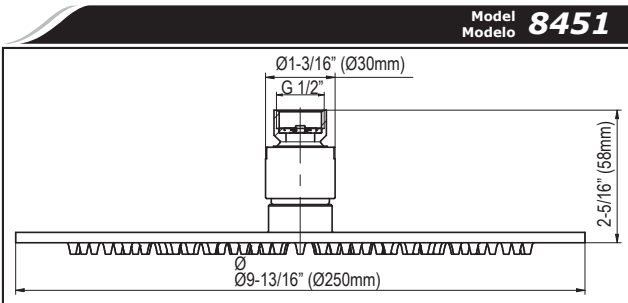
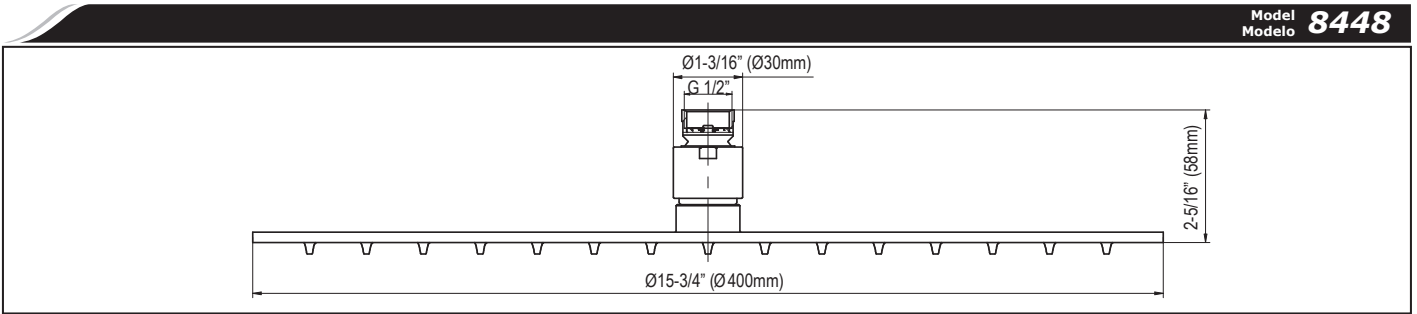
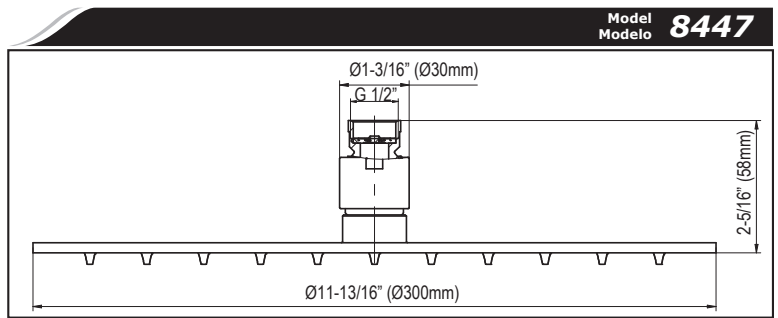
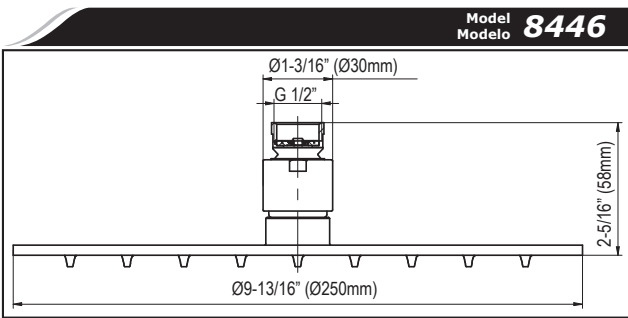

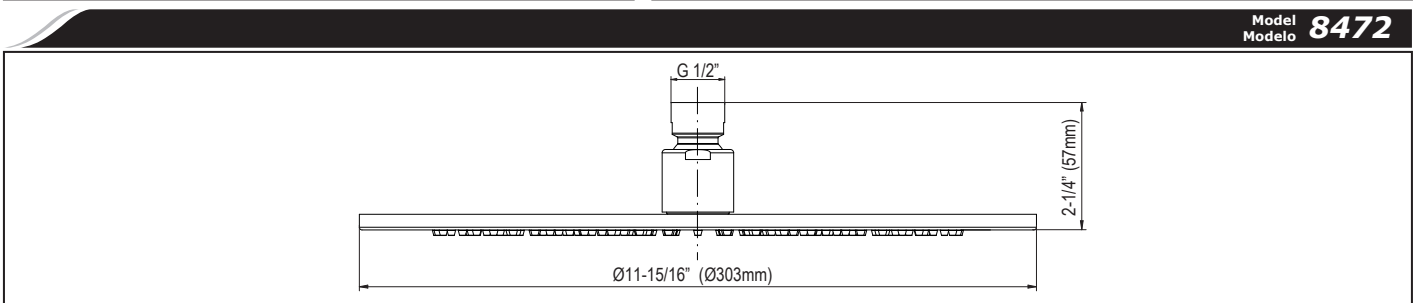
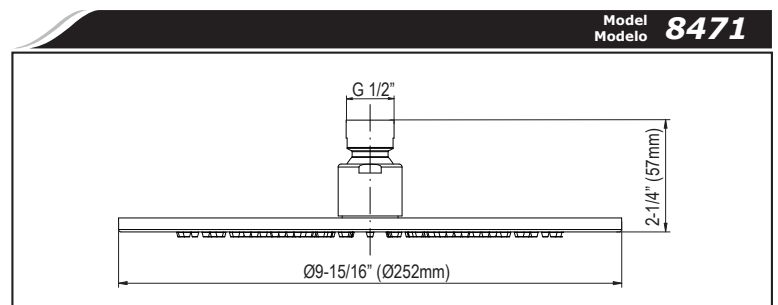
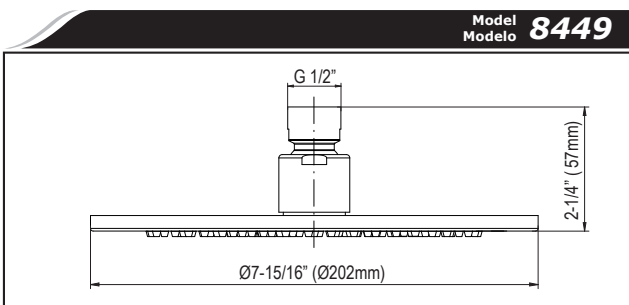
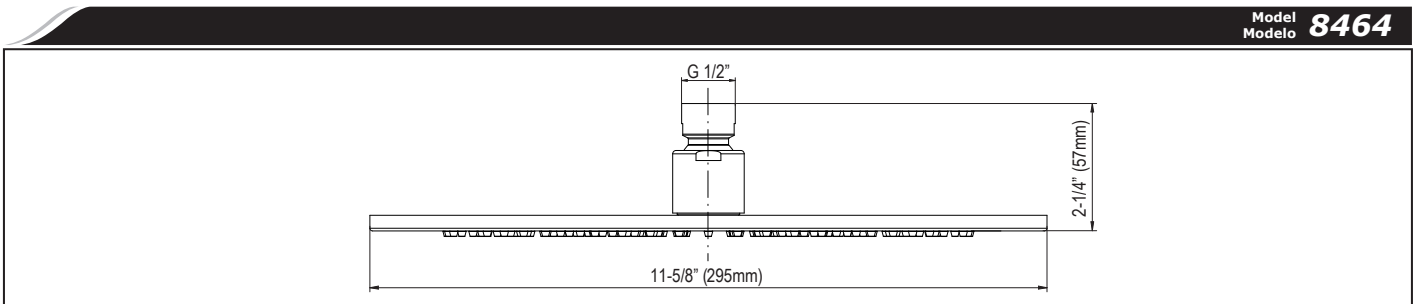
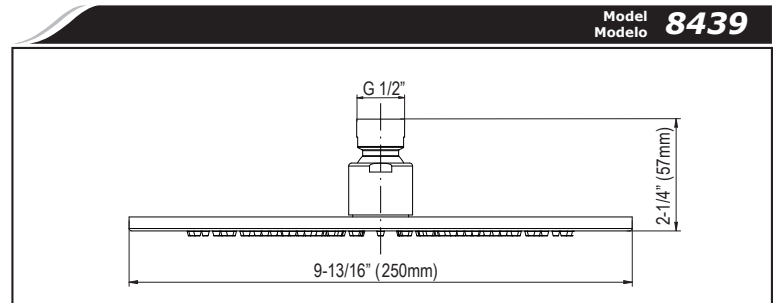
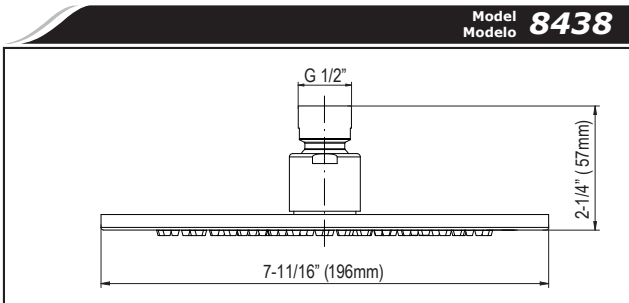
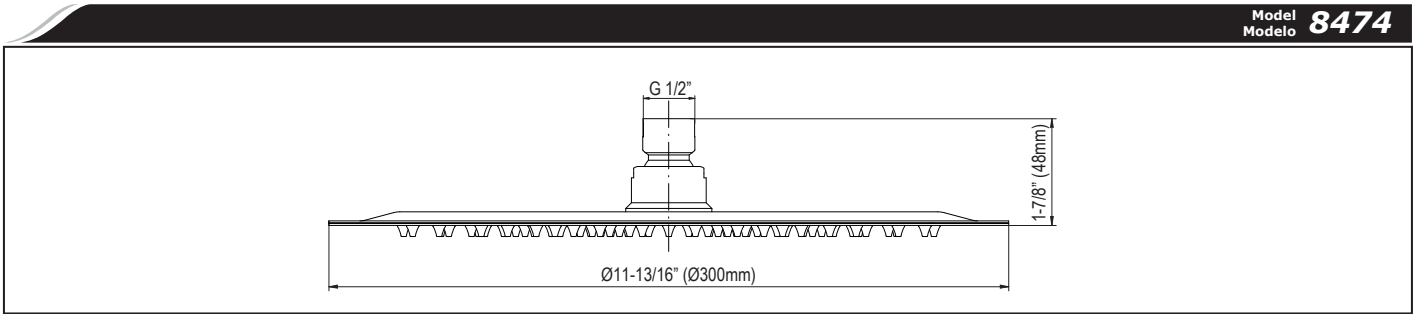
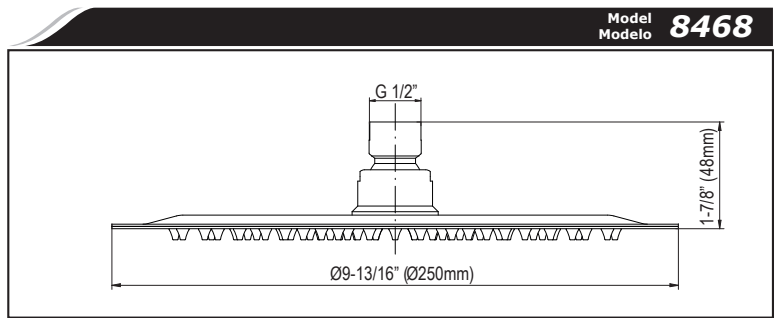
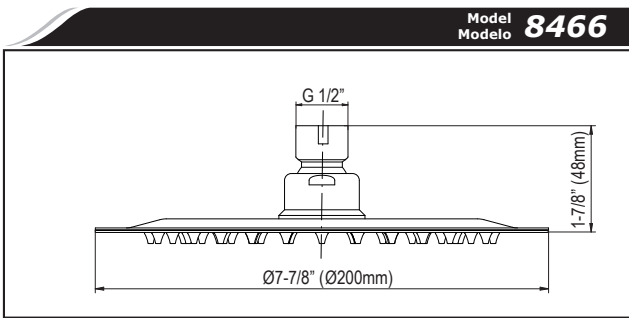

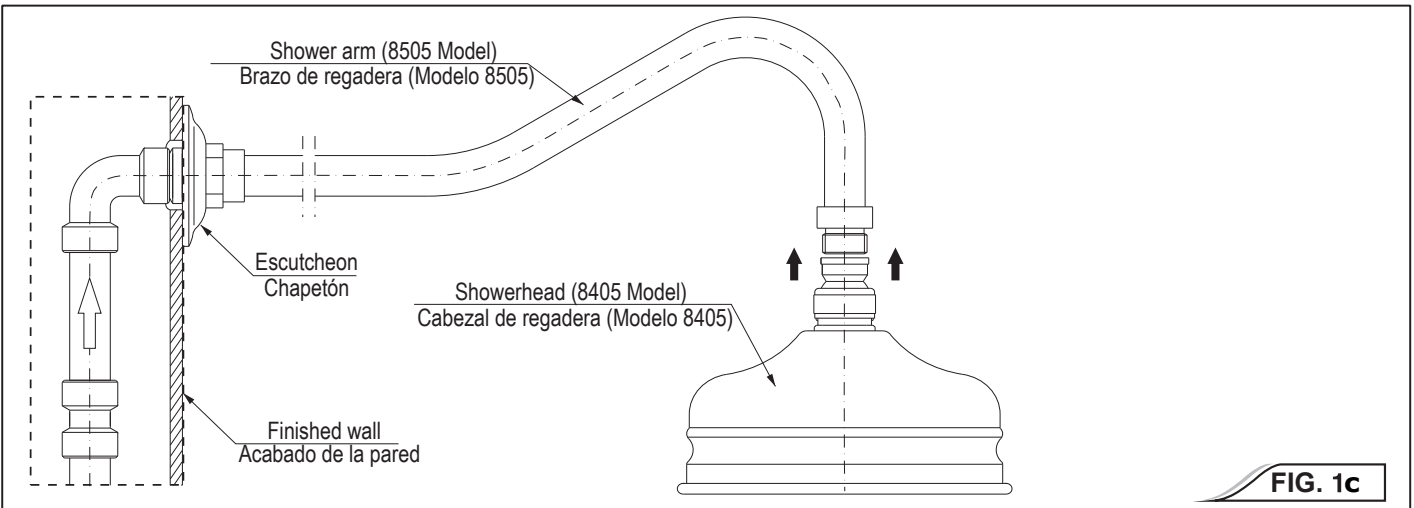
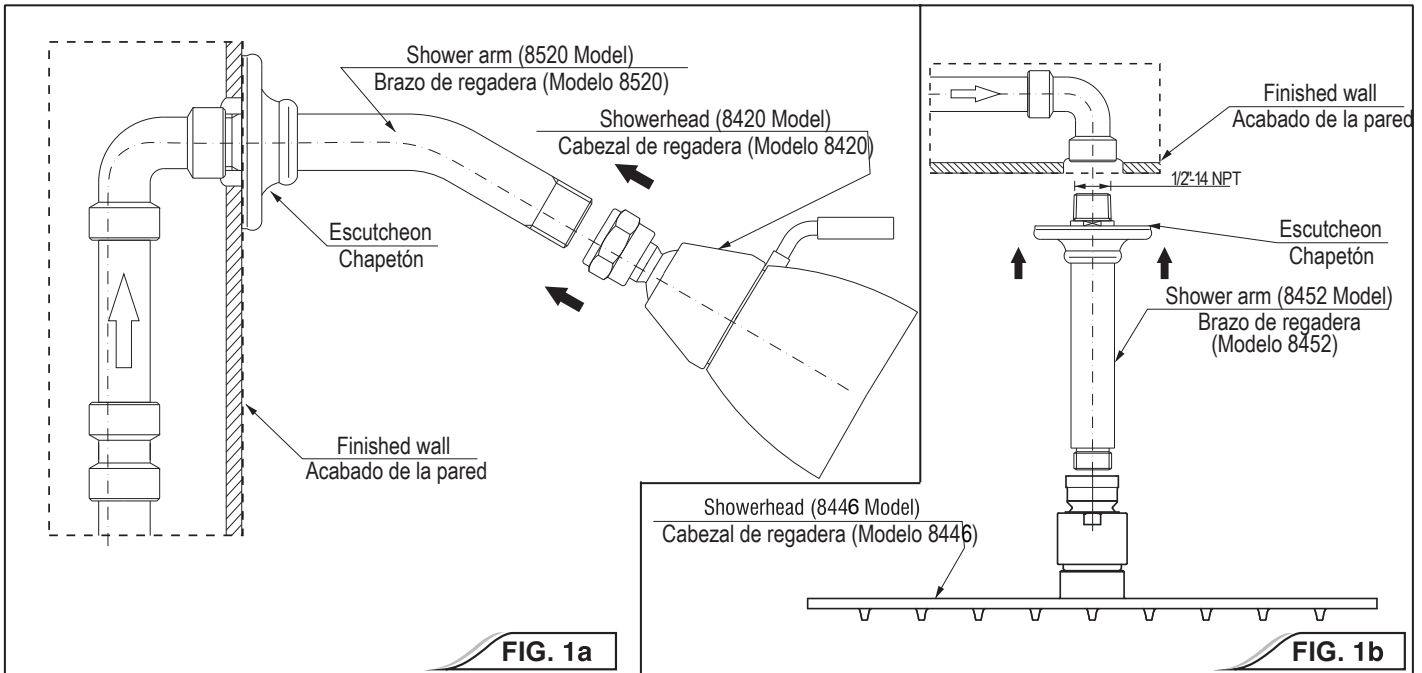

CARE AND MAINTENANCE • CUIDADO Y MANTENIMIENTO

ENGLISH

Your *Graff* product is designed and engineered in accordance with the highest quality and performance standards. Be sure not to damage the finish during installation. Care should be given to the cleaning of this product. Although its finish is extremely durable, it can be damaged by harsh abrasives or polish. **Never use abrasive cleaners, acids, solvents, etc. to clean any *Graff* product. To clean, simply wipe gently with a damp cloth and blot dry with a soft towel.**

Regularly wipe the lower part of the rainshower head thoroughly (with your palm or a soft cloth), once every 1-2 months, in order to remove any dirt from the nozzles. Failing to do so may result in damage to the casing of the rain shower head.

ESPAÑOL

Su producto de la *Graff* está diseñado y dirigido acuerdo con los estándares de funcionamiento y calidad más altos. Este seguro no dañar las terminaciones del grifo durante la instalación. Cuide el producto manteniéndolo siempre limpio. Aunque su acabado es extremadamente durable, puede ser dañado por los abrasivos o pulientes ásperos. **Nunca utilice limpiadores abrasivos, ácidos, solventes, el etc. para limpiar cualquier producto de la *Graff*. Para limpiar, simplemente use un paño húmedo y seque con una toalla suave. Periódicamente (1-2 veces al mes), limpie la parte inferior del rociador de ducha (con la mano o con un paño suave) para eliminar la suciedad acumulada en las boquillas. La falta de limpieza periódica puede provocar el deterioro de su superficie.**

WARRANTY • GARANTÍA

ENGLISH

Warranty conditions and warranty registration card are outlined on a separate sheet.

ESPAÑOL

Las condiciones de la garantía y la tarjeta del registro de la garantía se encuentran en una pagina separada.

**GENERAL GUIDLINES FOR PLANNING SHOWER SYSTEM
INSTRUCCIONES GENERALES PARA PLANEAR EL SISTEMA DE LA DUCHA**

Custom shower configuration for 3/4" thermostatic valve
Configuración ejemplar de ducha para la válvula termostática 3/4"

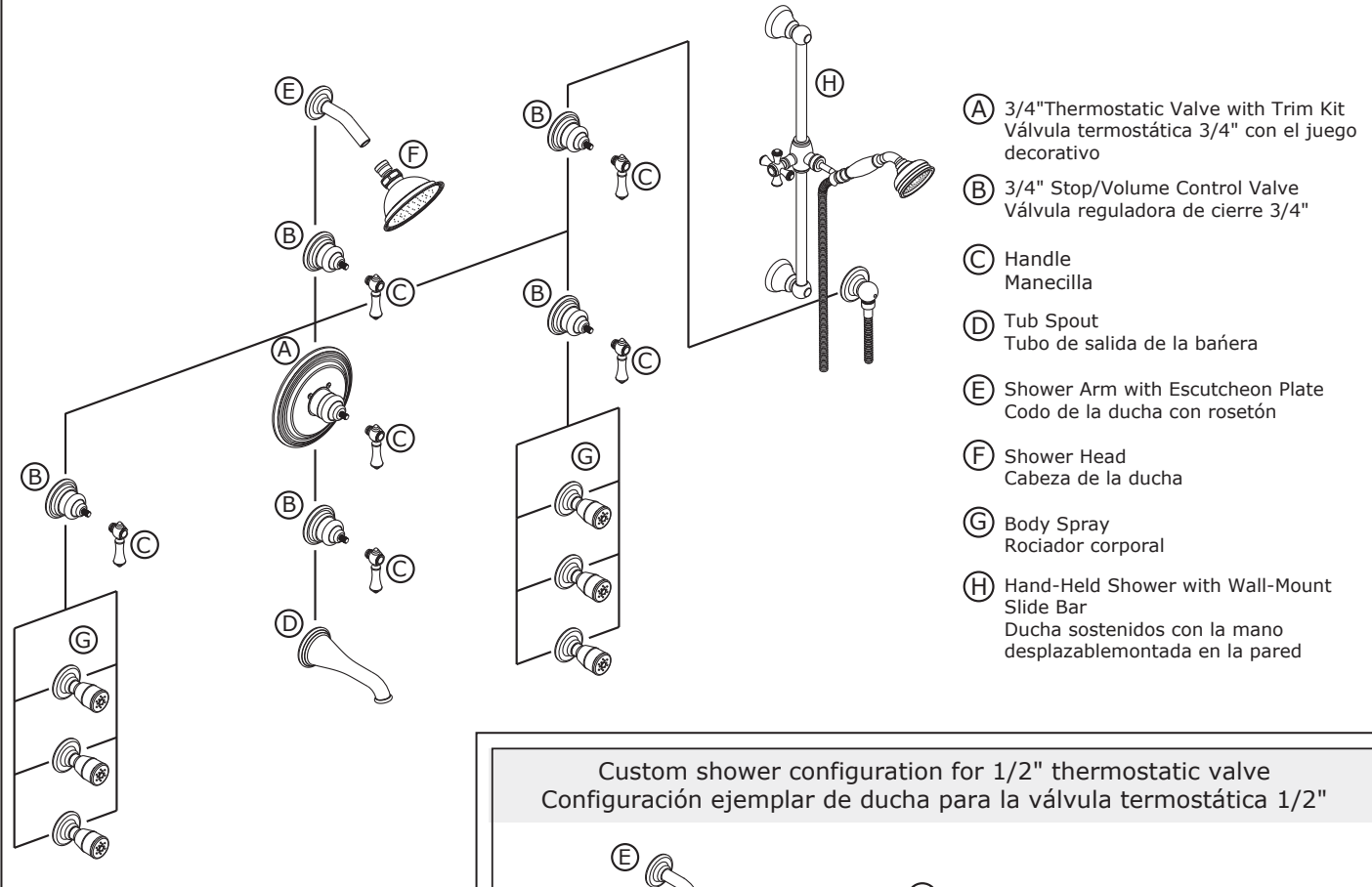

- (A) 3/4" Thermostatic Valve with Trim Kit
Válvula termostática 3/4" con el juego decorativo
- (B) 3/4" Stop/Volume Control Valve
Válvula reguladora de cierre 3/4"
- (C) Handle
Manecilla
- (D) Tub Spout
Tubo de salida de la bañera
- (E) Shower Arm with Escutcheon Plate
Codo de la ducha con rosetón
- (F) Shower Head
Cabeza de la ducha
- (G) Body Spray
Rociador corporal
- (H) Hand-Held Shower with Wall-Mount Slide Bar
Ducha sostenidos con la mano desplazable montada en la pared

Custom shower configuration for 1/2" thermostatic valve
Configuración ejemplar de ducha para la válvula termostática 1/2"

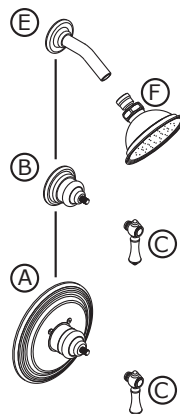

- (A) 1/2" Thermostatic Valve with Trim Kit
Válvula termostática 1/2" con el juego decorativo
- (B) 1/2" Stop/Volume Control Valve
Válvula reguladora de cierre 1/2"
- (C) Handle
Manecilla
- (E) Shower Arm
Codo de la ducha
- (F) Shower Head
Cabeza de la ducha

**HOTLINE FOR HELP
NUMERO DE EMERGENCIA**

For toll-free information and answers to your questions, call:
Llame sin costo para obtener información y respuestas a sus preguntas:



1 - 800 - 954 - GRAF (4723)

www.graff-faucets.com

All dimensions and drawings are for reference only. For details, please refer to actual products.
Todas las dimensiones y dibujos sirven únicamente de referencia. Para consultar detalles, ver los productos.